

# ROMA

*Eterna bellezza*



**FAP**  
CERAMICHE  
Naturalmente casa.

# ROMA

*Eterna bellezza*

8

STATUARIO

22

GRAFITE

26

TRAVERTINO

34

PIETRA

44

IMPERIALE

54

CALACATTA







## WALL & FLOOR

*Roma è un progetto ceramico completo di pavimenti e rivestimenti per circondare di bellezza i vostri spazi.*

*Roma is a complete ceramic programme of floor and wall tiles to encase your rooms with a sensation of beauty.*

---

Roma représente un projet céramique complet composé de sols et de murs qui saura valoriser vos espaces de vie. / Roma ein vollständiges Keramikprojekt für Fußböden und Verkleidungen der Ihren Raum mit Schönheit umgibt. / Roma es un proyecto cerámico completo de pavimentos y revestimientos para inundar vuestros espacios de belleza. / Roma — это универсальный проект напольной и настенной плитки, приносящей в ваш дом истинную красоту.



# MARMO E PIETRA MARBLE & STONE

*Roma esprime con fascino contemporaneo la bellezza del marmo e della pietra. Sei colori interpretano con grandi lastre una nuova estetica progettuale, senza limiti, senza tempo.*

*Roma lends contemporary appeal to the beauty of marble and stone. Six colours and large slabs for a new aesthetic project that is timeless and knows no limits.*



MARBRE ET PIERRE. Roma exprime la beauté du marbre et de la pierre avec un charme contemporain. Sur de grandes plaques, six couleurs interprètent une nouvelle esthétique conceptuelle, sans limite et sans contrainte. / MARMOR UND STEIN. Roma bringt die Schönheit des Marmors und des Steins mit zeitgemäßen Charme zum Ausdruck. Sechs Farben interpretieren mit großen Platten eine neue Planungsästhetik, grenzenlos und zeitlos. / MARMOL Y PIEDRA. Roma refleja con un moderno atractivo la belleza del mármol y de la piedra. Seis colores interpretan junto con grandes losas una nueva estética proyectual sin límites ni tiempo. / Мрамор и КАМЕНЬ. Roma передает в современном ключе красоту мрамора и камня. В шести тональностях крупноформатной плитки выражена новая дизайнерская эстетика: без границ и вне времени.

# STATUARIO

*puro e perfetto / pure and perfect*

PASTA BIANCA  
WHITE BODY

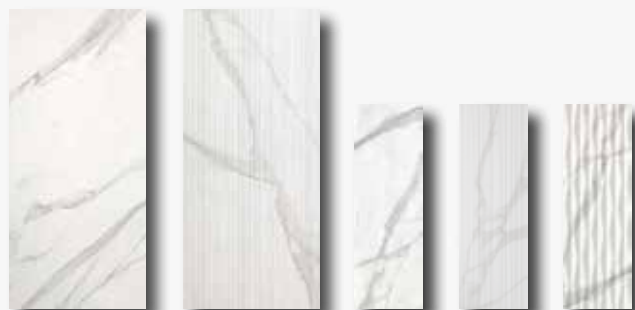

50x120 RT

50x120 RT

25x75

25x75

25x75

GRES PORCELLANATO  
PORCELAIN STONEWARE



80x80 RT

60x60 RT

30x60 RT

pur et parfait  
Perfekt und rein  
puro y perfecto  
чистая и безупречная





# MY LIVING

*Pavimento e rivestimento, il puro fascino dello Statuario e del grande formato.*

*Wall and floor coverings, the pure attraction of Statuario and large size.*



*Sols et murs, le charme de Statuario et du grand format à l'état pur. / Fußboden und Wandverkleidung, der reine Charme des Statuario und des großen Formats. / Pavimento y revestimiento, la atracción pura del Statuario y del gran formato. / Настенная и напольная плитка, непревзойденное очарование линии Statuario и крупного формата.*





**Wall**  
Roma Statuario  
Roma Filo Statuario

**Floor**  
Roma Statuario



# LA SUPERFICIE DECORA SURFACES FOR DECORATION

*Tridimensionale nella struttura Filo, o elegante fondo, è sempre la materia la vera decorazione.  
Whether it is the three dimensional texture of Filo or the elegant tile, the real decoration is always the material.*



**C'EST LA MATIERE QUI DECORE.** Tridimensionnel dans sa structure Filo, ou élégante base unie, c'est la matière qui constitue la véritable décoration. / **DIE OBERFLÄCHE DEKORIERT.** Das 3D- Dekor Filo oder eine elegante Grundfliese, die Dekoration liegt immer in der Materie. / **LA SUPERFICIE DECORA.** Tridimensional en la estructura Filo, o fondo elegante, la materia resulta ser siempre la auténtica decoración. / **ПОВЕРХНОСТЬ УКРАШАЕТ.** Объемная структура Filo или элегантная фоновая плитка — в центре внимания неизменно сам материал.



Wall  
Roma Statuario  
Roma Natura  
Statuario Mosaico



*Mosaico Natura,  
listello cromato Silver  
e il formato del rivesti-  
mento 25x75 rendono  
tutto contemporaneo.*

*Natura Mosaic, Silver  
chrome listel and the  
25x75 wall covering  
shape make everything  
look contemporary.*

Mosaïque Natura, listel chromé Silver et format 25x75 au mur, une association qui apporte à l'espace une réelle touche de modernité. / Mosaik Natura, die verchromte Leiste Silver und die Wandverkleidung im Format 25x75 lassen alles zeitgemäß erscheinen. / Mosaico Natura, listel cromado Silver y el formato del revestimiento 25x75 confieren siempre modernidad. / Мозаика Natura, хромированный бордюр Silver и формат настенной плитки 25x75 преобразуют помещение в современном стиле.





**Stair**  
Roma Statuario

**Floor**  
Roma Grafite

# UNA MATERIA SENZA TEMPO

## A TIMELESS MATERIAL

*Una gamma completa di pezzi speciali per coordinare perfettamente ogni ambiente della casa. Pavimento, scalino e battiscopa.*

*A full range of trim tiles to coordinate all the spaces in the home to perfection. Flooring, step and skirting tiles.*

---

UNE MATIÈRE INTEMPORELLE. Un programme complet de pièces spéciales pour revêtir à la perfection chaque espace de la maison. Sol, marche et plinthe. / EINE ZEITLOSE MATERIE. Eine vollständige Auswahl von Spezialteile für eine perfekte Raumkoordination Ihres Heims. Fußboden, Stufe und Fußleiste. / UNA MATERIA A TEMPORAL. Una gama completa de piezas especiales para coordinar a la perfección cada ambiente de la vivienda. Pavimento, escalera y zócalo. / НЕПРЕХОДЯЩАЯ МАТЕРИЯ. Идеальное завершение всех помещений вашего дома благодаря полной гамме специальных элементов. Напольная плитка, ступенька и плинтус.

# SHOP SIMPLY CHIC

*Una grande bellezza per realizzare spazi commerciali contemporanei.  
Il vero lusso: personalizzarli con sofisticate decorazioni.*

*True beauty for contemporary commercial applications.  
True luxury: customisation with sophisticated decorations.*



Le maximum de l'esthétique pour réaliser des espaces commerciaux contemporains. Et pour encore plus de classe, apportez leur une touche de personnalité avec quelques décors. / Eine wunderbare Schönheit für die Erschaffung von zeitgemäßen kommerziellen Räumlichkeiten. Der wahre Luxus: Personalisierung mit raffinierten Dekorationen. / Una gran belleza para realizar espacios comerciales contemporáneos. El auténtico lujo: personalizarlos con sofisticadas decoraciones. / Красота стиля для реализации современных деловых помещений. Придание индивидуальности благодаря изысканным декорам — это настоящая роскошь.

Wall  
Roma Statuario  
Floor  
Roma Righe Statuario Grafite Matt



# GRAFITE

*elegante e profondo / elegant and profound*

GRES PORCELLANATO  
PORCELAIN STONEWARE

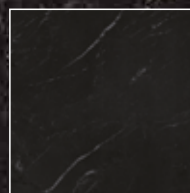

80 x 80 RT

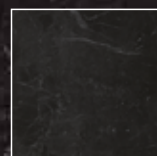

60 x 60 RT

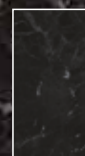

30 x 60 RT

élégant et profond  
Elegant und tief  
elegante y profundo  
элегантная и глубокая



# ELEGANT CONTEMPORARY

*La seduzione del marmo e  
l'affidabilità del gres porcel-  
lanato: partner perfetti per  
locali esclusivi.*

*The seduction of marble and  
the reliability of porcelain  
stoneware: ideal partners for  
exclusive spaces.*



**Wall**  
Roma Statuario  
**Floor**  
Roma Grafite

La séduction  
du marbre et  
la fiabilité du  
grès cérame :  
des partenaires  
parfaits pour  
des espaces  
exclusifs. / Die  
Verführung des  
Marmors und die  
Zuverlässigkeit  
des Feinsteinzeu-  
gs: Perfekte Part-  
ner für exklusive  
Räume. /  
La seducción  
del mármol y  
la fiabilidad del  
gres porcelánico:  
excelente com-  
binación para lo-  
cales exclusivos.  
/ Очарование  
мрамора и  
надежность  
керамогранита:  
идеальное  
сочетание для  
оформления  
эксклюзивных  
помещений.



# TRAVERTINO

*ricco e naturale / rich and natural*

riche et naturel  
Reich und natürlich  
rico y natural  
роскошная и естественная

PASTA BIANCA  
WHITE BODY



25 x 75    25 x 75

GRES PORCELLANATO  
PORCELAIN STONEWARE



80 x 80 RT    60 x 60 RT    30 x 60 RT





**Wall**  
Roma Travertino  
Roma Filo Travertino  
Roma Natura Travertino Mosaico

**Floor**  
Roma Travertino Matt



## FASCINO NATURALE NATURAL ATTRACTION

*Naturali striature circondano lo spazio. Nella doccia, il mosaico Natura e la versatile materia esprimono soluzioni architettoniche affascinanti.*

*Natural veins encasing the space. In the shower, the Natura mosaic and the versatile material express attractive architectural solutions.*



CHARME NATUREL. Les striures naturelles présentes entourent l'espace. Dans la douche, la mosaïque Natura et la matière très éclectique donnent naissance à des solutions architectoniques particulièrement intéressantes. / NATÜRLICHER CHARME. Natürliche Verläufe umgeben den Raum. In der Dusche strahlen das Mosaik Natura und die vielseitige Materie charmante architektonische Lösungen aus. / ATTRACTIVO NATURAL. Vetas naturales rodean el espacio. En la ducha, el mosaico Natura y la versátil materia muestran excelentes soluciones arquitectónicas. / ОЧАРОВАНИЕ ПРИРОДЫ. Естественное рифление наполняет пространство. В душевой кабине мозаика Natura и многофункциональная керамика воплощают восхитительные архитектурные решения.





# GLAM GYM

*Atmosfera sofisticata,  
sensazioni naturali.*

*Sophisticated atmosphere,  
natural sensations.*

**Wall**  
Roma Travertino

**Floor**  
Roma Travertino

Une atmosphère captivante,  
des sensations naturelles. /  
Raffinierte Atmosphäre, natür-  
liche Sensationen. / Atmós-  
fera sofisticada, sensaciones  
naturales. / Утонченная  
атмосфера, соприкосновение  
с природой.



# PIETRA

*raffinata e accogliente / elegant and inviting*

raffinée et accueillante  
Raffiniert und einladend  
refinada y acogedora  
изысканная и уютная

PASTA BIANCA  
WHITE BODY



50x120 RT



50x120 RT



25x75



25x75

GRES PORCELLANATO  
PORCELAIN STONEWARE



80x80 RT



60x60 RT



30x60 RT





**Wall**

Roma Pietra  
Roma Filo Pietra  
Roma Pietra Mosaico

**Floor**

Roma Pietra Matt





*Differenti e morbide vibrazioni di luce decorano la materia in un mood perfettamente coordinato.*

*The soft and changing shimmering light decorates the material with a mood that is perfectly coordinated.*



*Des reflets de lumière, doux et ondoyants, animent cet espace ou tout apparait coordonné avec juste équilibre. / Verschiedene und sanfte Vibrationen von Licht schmücken die Materie in einem perfekt koordinierten Mood. / Distintas vibraciones suaves de luz decoran la materia con un estilo perfectamente coordinado. / Разнообразные мягкие световые блики придают плитке безупречное единство стиля.*





**Wall**  
Roma Pietra  
Roma Classic Pietra  
Roma Classic Pietra Listello  
**Floor**  
Roma Pietra Matt

## NEW CLASSIC



*L'eleganza tridimensionale del decoro Classic sul calore screziato della Pietra: un nuovo classico che sorprende per contemporaneità.*

*The three dimensional elegance of the Classic decoration on the grainy warmth of Pietra: a new classic whose contemporary mood is astonishing.*

*L'élégance et le chic du relief du décor Classic en opposition à l'ardeur jaspée de Pietra : un classique insolite qui surprend par sa modernité. / Die 3D-Eleganz des Dekors Classic auf dem natürlichen Farbverlaufs des Pietra: ein neuer Klassiker, der mit seinem modernen Einklang überrascht. / La elegancia tridimensional de la decoración Classic en el cálido vetado de la Pietra: un nuevo clásico que sorprende por su modernidad. / Элегантность трехмерного декора Classic выражена теплыми крапинками Pietra: новая классика, поражающая своей современностью.*



*Pietra e Imperiale, un abbinamento sofisticato, esaltato dalle infinite possibilità progettuali di Roma.*

*Pietra and Imperiale a sophisticated combination emphasised by the infinite design possibilities of Roma.*



**Wall**  
Roma Pietra  
Roma Imperiale  
Roma Natura Imperiale Mosaico

**Floor**  
Roma Imperiale



*Pietra et Imperiale, un mariage recherché, relevé par les innombrables possibilités conceptuelles de Roma. / Pietra und Imperiale, eine raffinierte Kombination mit unendlichen Planungsmöglichkeiten von Roma. / Pietra e Imperiale, una sofisticada combinación exaltada por infinitas posibilidades proyectuales de Roma. / Pietra и Imperiale, утонченное сочетание, подчеркнутое бесконечными дизайнерскими возможностями Roma.*



# IMPERIALE

*s sofisticato e singolare / sophisticated and unusual*

sophistiqué et singulier  
Raffiniert und einmalig  
sofisticado y singular  
утонченная и уникальная

PASTA BIANCA  
WHITE BODY



50x120 RT



50x120 RT



25x75

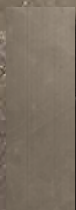

25x75

GRES PORCELLANATO  
PORCELAIN STONEWARE



80x80 RT



60x60 RT



30x60 RT





**Wall**  
Roma Imperiale  
Roma Filo Pietra

**Floor**  
Roma Imperiale



# WELCOME STYLE

*Roma, la collezione perfetta per donare alla vostra accoglienza lo stile desiderato.  
Roma, the ideal collection to welcome your guests in perfect style.*



Roma, la toile de fond idéale pour recevoir vos amis dans un cadre d'un grand style. / Roma, die perfekte Kollektion die Ihrem Empfang und Begrüßung den gewünschten Stil verleiht. / Roma, la colección perfecta para otorgarle a su recibimiento el estilo deseado. / Roma, идеальная коллекция для придания вашему гостеприимству индивидуального стиля



**Wall**  
Roma Filo Imperiale  
**Floor**  
Roma Imperiale





**Wall**  
Roma Imperiale  
Roma Filo Imperiale  
**Floor**  
Roma Imperiale Matt

## BELLEZZA AVVOLGENTE ENVELOPING BEAUTY

*Ogni lastra è un pezzo unico.  
Una naturale meraviglia fatta di  
differenti e spontanee venature.*

*Each slab is unique. A natural  
wonder made up of different and  
spontaneous veins.*



UNE BEAUTÉ CAPTIVANTE. Chaque plaque est une pièce unique. Une merveille naturelle faite de veinures variées et spontanées. / MITREISSENDE SCHÖNHEIT. Jede Platte ist einzigartig. Ein natürliches Wunder, welches aus unterschiedlichen Verläufe besteh. / ENCANTADORA BELLEZA. Cada losa es una pieza única. Una maravilla natural hecha con diferentes y espontáneas vetas. / ЧАРУЮЩАЯ КРАСОТА. Каждая плитка — это уникальный элемент, будто созданный самой природой из неодинаковых произвольных прожилок.





*La materia è qui protagonista come decorativo drappeggio e come elemento essenziale per un perfetto piano lavabo.*

*Here the material is in the spotlight in decorative folds and an essential element for a perfect top for a washbasin.*



*La matière joue ici un rôle de drapé décoratif et d'élément essentiel, pour un plan de toilette parfait. / Die Materie, Hauptdarsteller als dekorativer Vorhang und als essentielles Element für ein perfektes Waschbecken. / La materia es aquí protagonista como decoración drapeada y elemento esencial para una perfecta encimera de lavabo. / Материя выступает здесь и как роскошная драпировка, и как основной элемент в оформлении зоны раковины.*



# CALACATTA

*caldo e pregiato / warm and precious*

prestigieux et chaleureux  
Warm und wertvoll  
cálido y precioso  
Теплая и драгоценная

PASTA BIANCA  
WHITE BODY



50 x 120 RT

50 x 120 RT

25 x 75

25 x 75

25 x 75

GRES PORCELLANATO  
PORCELAIN STONEWARE



80 x 80 RT

60 x 60 RT

30 x 60 RT





**Wall**  
Roma Calacatta

**Floor**  
Roma Calacatta



# RAFFINATO CALORE ELEGANT WARMTH

*80x160, la meraviglia del marmo,  
la praticità del Gres porcellanato.*

*80x160, the wonder of marble,  
the practical features of porcelain stoneware.*

UNE CHALEUR ENVELOPPANTE. 80x160, le charme du marbre, les qualités pratiques du grès cérame. / RAFFINIERTA WÄRME. 80x160, wunderbarer Marmor und praktisches Feinsteinzeug. / REFINADO CALOR. 80x160, la maravilla del mármol, la practicidad del Gres porcelánico. / ИЗЫСКАННОЕ ТЕПЛО. 80x160 - красота мрамора, практичность керамогранита.





**Wall**  
Roma Calacatta

**Floor**  
Roma Calacatta Micromosaico



*Raffinato e decò: Roma possiede tutti gli elementi decorativi necessari per realizzare lo stile che desideri.*

*Elegant and decò: Roma has all the decorative elements you need to create the style you want.*



**Wall**

Roma Calacatta Alzata  
Roma Fold Calacatta  
Roma Calacatta Matita  
Roma Greca Calacatta Listello  
Roma Calacatta  
Roma Calacatta London

**Floor**

Roma Calacatta



*Raffiné et decò : Roma possède tous les éléments décoratifs nécessaires aux recherches de style les plus exigeantes. / Raffiniert und decò: Roma besitzt sämtliche dekorative Elemente für die Realisierung des gewünschten Stils. / Refinada y decò: Roma posee todos los elementos decorativos necesarios para realizar el estilo deseado. / Изысканность и decò: плитка Roma включает все декоративные элементы, необходимые для воплощения вашего персонального стиля.*





Wall  
Roma Calacatta  
Roma Filo Calacatta





# VERI INTARSI REAL INTARSIA

*Dalla materia incisa emergono  
delicate decorazioni.*

*Delicate decorations emerge  
from the engraved material.*

DE VÉRITABLES MARQUETTERIES.  
De la matière incisée naissent  
d'élégants décors. / ECHTE IN-  
TARSIEN. Die eingravierte Materie  
lässt zarte Dekorationen entstehen.  
/ AUTÉNTICOS INSERTOS. De la  
materia incisa emergen delicadas  
decoraciones. / НАСТОЯЩАЯ  
ГРАВИРОВКА. Гравированная  
плитка превращается в истинное  
украшение.



# SIAMO CERAMICA

UNA SCELTA CONSAPEVOLE

# WE ARE CERAMICS

A MINDFUL CHOICE

NON BRUCIA  
DOES NOT BURN

SICURA PER LA SALUTE  
SAFE FOR HEALTH

IL MASSIMO DELL'IGIENE  
MAXIMUM HYGIENE

RESISTE A TUTTO  
RESISTANT TO EVERYTHING

VERSATILE  
VERSATILE

ECOLOGICA  
ECO-FRIENDLY

comunicazione e marketing in partnership con:  
community e social media in partnership with:

**ceramica**.info

[www.ceramica.info](http://www.ceramica.info)



# Gres porcellanato pezzi speciali

## Porcelain Stoneware special trims

Pièces spéciales grès cérame

Feinsteinzeug-formteile

Piezas especiales gres porcelánico

Специальные элементы из керамогранита

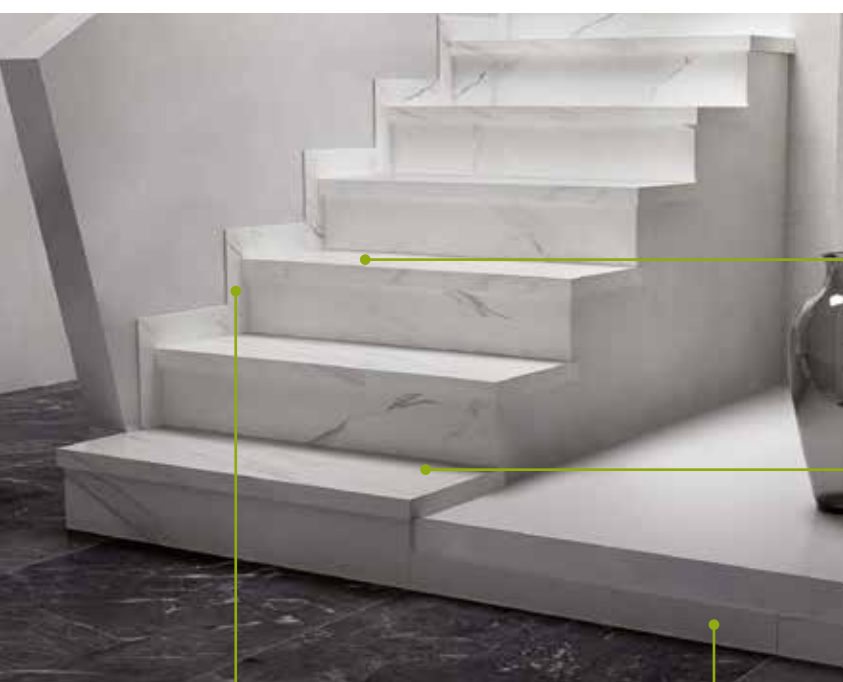

SCALINO

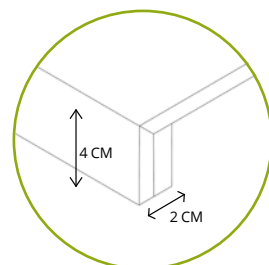

SCALINO ANGOLARE

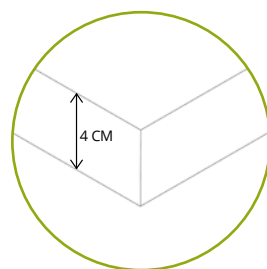

BATTISCOPIA SAGOMATO

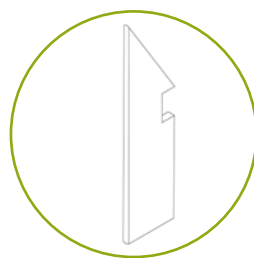

BATTISCOPIA

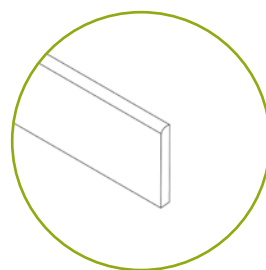

# Destinazione d'uso

## Destination of use

Utilisation prévue

Verwendungszweck

Destinos de uso

Область применения

### MEDIUM WALKING

ambienti commerciali medi con accessi non diretti con l'esterno o protetti da zerbini come ristoranti, bar, negozi, hotel, biblioteche, business lounge, banche, ad esclusione di passaggi obbligati. Ideale anche per ambienti residenziali.

commercial environments with medium foot traffic: with non-direct outside access or access protected with doormats, such as restaurants, bars, shops, hotels, libraries, business lounges, banks, except for areas with obligatory passages. Also ideal for residential settings



espaces commerciaux soumis à un piétinement moyen avec accès non directs de l'extérieur ou protégés par des paillasons, tels que les restaurants, les cafés, les boutiques, les hôtels, les bibliothèques, les espaces affaires et les banques, à l'exception des lieux de passage obligatoires. Idéal aussi dans les espaces résidentiels.

Gewerberäume mit mittlerer Begehungsfrequenz: Räumlichkeiten ohne direkten Zugang von außen oder durch Fußmatten geschützte Bereiche wie Restaurants, Bars, Geschäfte, Hotels, Bibliotheken, Business Lounges und Banken mit der Ausnahme von Durchgangsbereichen. Auch für den Wohnbereich ideal.

ambientes comerciales medios: con accesos indirectos al exterior o protegidos por felpudos como restaurantes, bares, tiendas, hoteles, bibliotecas, business lounge, bancos, exceptuándose los pasajes obligatorios. Perfecto también para ambientes residenciales.

деловые помещения со средним уровнем проходимости: без прямого выхода на улицу или защищенные входными ковровыми покрытиями: рестораны, магазины, гостиницы, библиотеки, бизнес-залы, банки, за исключением обязательных зон прохода. Идеально подходит для жилых пространств.



# Wall tiles

Piastrelle rettificate in pasta bianca,  
pareti senza fughe

Rectified white body tiles,  
jointless walls

Noi realizziamo piastrelle e ne tagliamo i bordi per renderle a “spigolo vivo”, questo permette di posarle senza fuga, così le pareti sono superfici continue, lisce e perfette, le fughe quasi invisibili. Oltre ai benefici estetici, non trattengono lo sporco e facilitano la pulizia.

We create tiles and cut the edges. These “sharp-edge” tiles can be laid without joints, for perfectly smooth, continuous surfaces, with the joints barely noticeable. In addition to the aesthetic advantages, these tiles prevent dirt from gathering and are thus easy to clean.

## FORMATS RECTIFIÉS, POSE À JOINT RÉDUIT

Nous réalisons des carreaux que nous rectifions pour obtenir des bords parfaitement droits qui permettent une pose à joints réduits. Les murs apparaissent ainsi plus uniformes et continus car le joint est presque invisible. Ceci constitue non seulement un avantage esthétique, les espaces apparaissent plus grands, mais également fonctionnel : la saleté s'y loge en effet moins facilement et l'entretien est plus aisé.

## GESCHLIFFENE FLIESEN, FUGENLOSE WÄNDE

Wir produzieren Fliesen und schneiden die Kanten, um «scharfe Kanten» zu erhalten. Dies bedeutet, dass sie nahtlos verlegt werden können, sodass die Oberflächen durchgehend, glatt und perfekt sind und die Fugen kaum sichtbar sind. Zusätzlich zu den ästhetischen Vorteilen wird Schmutz nicht eingeschlossen und die Reinigung wird erleichtert.

## LOSAS RECTIFICADAS, PAREDES SIN JUNTAS

Realizamos losas y cortamos los bordes para que sean de “arista viva”, lo que permite colocarlas sin juntas; de esta manera las superficies de las paredes son continuas, lisas y perfectas y las juntas son casi invisibles. Además de los beneficios estéticos, no retienen la suciedad y facilitan la limpieza.

## ОСНОВНАЯ ПЛИТКА, БЕСШОВНАЯ СТЕНКА

Мы производим плитки и дорабатываем края, чтобы создать «живой край». Это позволяет использовать бесшовную технику укладки, которая гарантирует непрерывность, гладкость и совершенство поверхностей с почти невидимыми швами. В дополнение к эстетическим преимуществам, этот стиль не задерживает грязь и облегчает стирку, отражают совершенное сочетание керамических традиций и находок современного дизайна.

## RETTIFICHIAMO LE PIASTRELLE CON UN TAGLIO LEGGERMENTE INCLINATO PER CONSENTIRE LA POSA ACCOSTATA:

- ▶ posa senza sbecatura
- ▶ penetrazione agevolata dello stucco

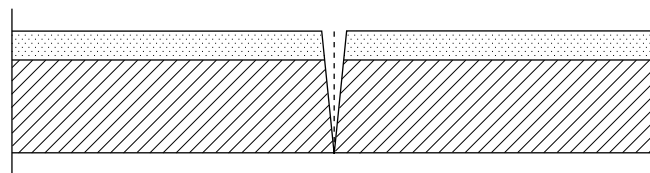

## WE RECTIFY THE TILES WITH A SLIGHTLY DIAGONAL CUT, ALLOWING FOR FLUSH LAYING:

- ▶ laying without cracks
- ▶ makes it easier for the grout to penetrate

## LA RECTIFICATION DES CARREAUX PRÉVOIT UNE COUPE AVEC UN LÉGER BIAIS POUR FACILITER LA POSE À JOINTS RÉDUITS :

- LES BORDS DES CARREAUX SONT MOINS EXPOSÉS À DES ÉCLATS
- LE MORTIER JOINT PÉNÈTRE PLUS FACILEMENT

## WIR SCHLEIFEN DIE FLIESEN MIT EINEM LEICHT GENEIGTEN SCHNITTWINKEL, UM SIE NEBENEINANDER VERLEGEN ZU KÖNNEN:

- VERLEGEN OHNE ANGESCHLAGENEN RÄNDER
- LEICHTERES EINDRINGEN DER FUGENMASSE

## RECTIFICAMOS LAS LOSAS CON UN CORTE LIGERAMENTE INCLINADO PARA PERMITIR LA COLOCACIÓN UNIDA:

- COLOCACIÓN SIN ASTILLADOS
- PENETRACIÓN FACILITADA DEL MORTERO DE REJUNTADO

## МЫ ВЫРАВНИВАЕМ КРАЯ ПЛИТКИ, ОБРЕЗАЯ ИХ ПОД ЛЕГКИМ НАКЛОНОМ, ЧТО ПОЗВОЛЯЕТ ПРОИЗВОДИТЬ БЕСШОВНУЮ УКЛАДКУ:

- УКЛАДКА БЕЗ НЕРОВНОСТЕЙ
- БЕСПРЕПЯТСТВЕННОЕ ПРОНИКНОВЕНИЕ ШТУКАТУРКИ

# PEZZI SPECIALI / TRIMS

## WALL TILES

PIÈCES SPÉCIALES / FORMTEILE /

PIEZAS ESPECIALES / СПЕЦИАЛЬНАЯ СЕКЦИЯ

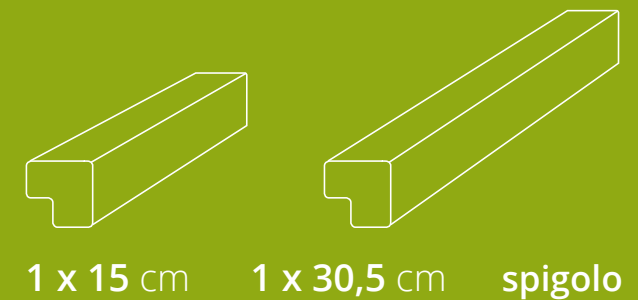

1 x 15 cm 1 x 30,5 cm spigolo





1 x 1 cm  
angolo esterno spigolo



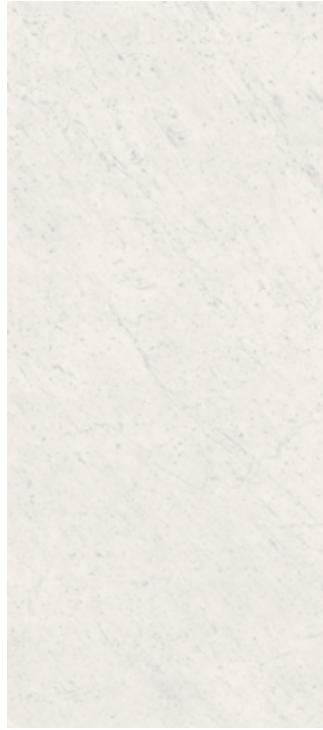

Roma Pietra Silk 120x278 RT V2 



Roma Carrara Silk 120x278 RT V2 



Roma Calacatta Silk 120x278 RT V3 

Questi articoli sono caratterizzati da una grande variabilità delle venature fra le lastre.  
These items feature a significant variability of veining effects on the slabs.



Wall: Roma Diamond Carrara Silk - Floor: Color > Now Grigio Silk

|  | Unità di vendita<br>Sales unit | MQ./Box | PZ./Box | Kg/Box | Box/PL |
|--|--------------------------------|---------|---------|--------|--------|
|  | 1 Box                          | 3,336   | 1       | 47,94  | 18     |





Roma Statuario Matt V3



Roma Grafite Matt V2



Roma Calacatta Matt V3



Roma Pietra Matt V2



Roma Imperiale Matt V2



Roma Travertino Matt V2

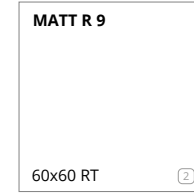
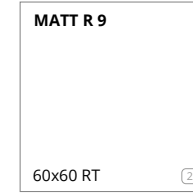
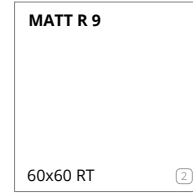
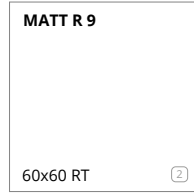
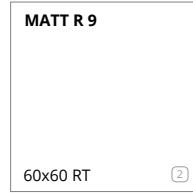
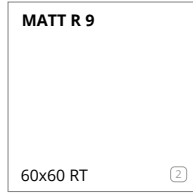
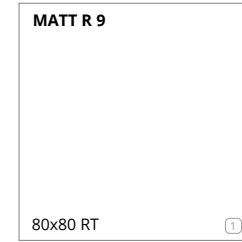
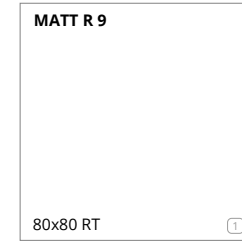
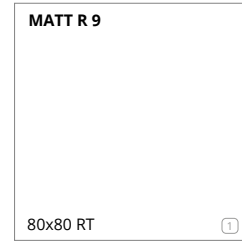
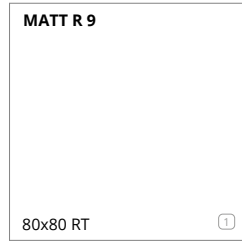
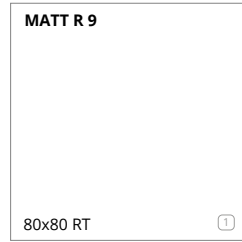
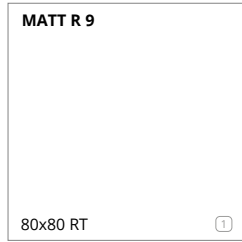

|   | Unità di vendita<br>Sales unit | MQ./Box | PZ./Box | Kg/Box | Box/PL |
|---|--------------------------------|---------|---------|--------|--------|
| ① | 1 Box                          | 1,280   | 2       | 24,90  | 48     |
| ② | 1 Box                          | 1,080   | 3       | 21,70  | 40     |
| ③ | 1 Box                          | 1,260   | 7       | 25,00  | 40     |

**Classification UPEC**  
Seul le site du CSTB fait foi, pour vérifier les classements indiqués, merci de consulter le site <https://evaluation.cstb.fr/>



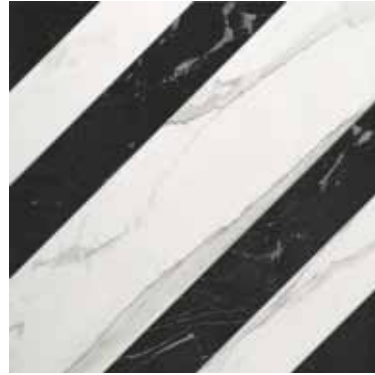

Roma Righe Statuario Grafite Matt  
Inserto 60x60 RT ①



Roma Righe Calacatta Imperiale Matt  
Inserto 60x60 RT ①



Roma Righe Matt Inserto

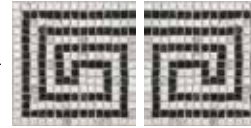

fMGU Roma Greca Statuario Grafite  
Mosaico Mix 2 20x40 ②



fMAQ Roma Angolo Greca Statuario Grafite  
Mosaico 20x20 ③



MOSAICO



Roma Round Statuario  
Mosaico\*\*\*  
29,5x32,5 ④



Roma Round Calacatta  
Mosaico\*\*\*  
29,5x32,5 ④



Roma Round Imperiale  
Mosaico\*\*\*  
29,5x32,5 ④



Roma Round Travertino  
Mosaico\*\*\*  
29,5x32,5 ④



Roma Round Pietra  
Mosaico\*\*\*  
29,5x32,5 ④

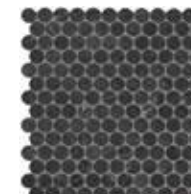

Roma Round Grafite  
Mosaico\*\*\*  
29,5x32,5 ④

MOSAICO ANTICATO



Roma Statuario  
Macromosaico Anticato  
30x30 ⑤



Roma Calacatta  
Macromosaico Anticato  
30x30 ⑤

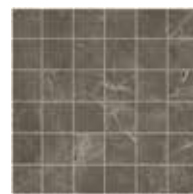

Roma Imperiale  
Macromosaico Anticato  
30x30 ⑤



Roma Travertino  
Macromosaico Anticato  
30x30 ⑤



Roma Pietra  
Macromosaico Anticato  
30x30 ⑤

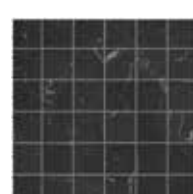

Roma Grafite  
Macromosaico Anticato  
30x30 ⑤



Roma Statuario  
Micromosaico Anticato\*  
30x30 ⑤



Roma Calacatta  
Micromosaico Anticato\*  
30x30 ⑤



Roma Imperiale  
Micromosaico Anticato\*  
30x30 ⑤



Roma Travertino  
Micromosaico Anticato\*  
30x30 ⑤



Roma Pietra  
Micromosaico Anticato\*  
30x30 ⑤

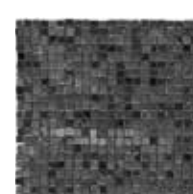

Roma Grafite  
Micromosaico Anticato\*  
30x30 ⑤



Roma Brick Statuario  
Mosaico Anticato\*\*  
30x30 ⑤



Roma Brick Calacatta  
Mosaico Anticato\*\*  
30x30 ⑤



Roma Brick Imperiale  
Mosaico Anticato\*\*  
30x30 ⑤



Roma Brick Travertino  
Mosaico Anticato\*\*  
30x30 ⑤



Roma Brick Pietra  
Mosaico Anticato\*\*  
30x30 ⑤



Roma Brick Grafite  
Mosaico Anticato\*\*  
30x30 ⑤

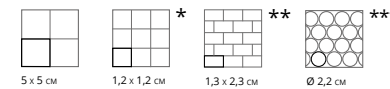

|   | Unità di vendita<br>Sales unit | MQ./Box | PZ./Box | Kg/Box | Box/PL |
|---|--------------------------------|---------|---------|--------|--------|
| ① | 1 Box                          | -       | 1       | 8,00   | -      |
| ② | 1 Box                          | -       | 2 MIX   | 3,20   | -      |
| ③ | 1 Box                          | -       | 4       | 3,20   | -      |
| ④ | 1 Box                          | 0,575   | 6       | 9,90   | 72     |
| ⑤ | 1 Box                          | 0,540   | 6       | 10,20  | 60     |





|   | Unità di vendita<br>Sales unit | MQ./Box | PZ./Box | Kg/Box | Box/PL |
|---|--------------------------------|---------|---------|--------|--------|
| ① | 1 Box                          | ML 6,40 | 8       | 8,24   | -      |
| ② | 1 Box                          | ML 4,80 | 8       | 6,70   | -      |
| ③ | 1 Box                          | -       | 8       | -      | -      |
| ④ | 1 Box                          | -       | 2       | -      | -      |

TRIMS

| ROMA   | STATUARIO | GRAFITE | CALACATTA | PIETRA | IMPERIALE | TRAVERTINO |
|--|-----------|---------|-----------|--------|-----------|------------|
| Battiscopa<br>7,2x80 RT 3"x31 <sup>1</sup> / <sub>2</sub> "                | Matt ①    | Matt ①  | Matt ①    | Matt ① | Matt ①    | Matt ①     |
| Battiscopa<br>7,2x60 RT 3"x23 <sup>5</sup> / <sub>8</sub> "                | Matt ②    | Matt ②  | Matt ②    | Matt ② | Matt ②    | Matt ②     |
| Battiscopa<br>Sagomato DX<br>7,2x30 RT 3"x11 <sup>3</sup> / <sub>4</sub> " | Matt ③    | Matt ③  | Matt ③    | Matt ③ | Matt ③    | Matt ③     |
| Battiscopa<br>Sagomato SX<br>7,2x30 RT 3"x11 <sup>3</sup> / <sub>4</sub> " | Matt ③    | Matt ③  | Matt ③    | Matt ③ | Matt ③    | Matt ③     |
| Scalino<br>33x80 RT 13"x31 <sup>1</sup> / <sub>2</sub> "                   | Matt ④    | Matt ④  | Matt ④    | Matt ④ | Matt ④    | Matt ④     |
| Scalino<br>33x60 RT 13"x23 <sup>5</sup> / <sub>8</sub> "                   | Matt ④    | Matt ④  | Matt ④    | Matt ④ | Matt ④    | Matt ④     |
| Scalino Angolare<br>33x33 RT 13"x13"                                       | Matt ④    | Matt ④  | Matt ④    | Matt ④ | Matt ④    | Matt ④     |







Roma Statuario 50x120 RT

V3  
①



Roma Filo Statuario 50x120 RT

V3  
②



Roma Calacatta 50x120 RT

V3  
①



Roma Filo Calacatta 50x120 RT

V3  
②



Roma Imperiale 50x120 RT

V2  
①



Roma Filo Imperiale 50x120 RT

V2  
②



Roma Pietra 50x120 RT

V2  
①



Roma Filo Pietra 50x120 RT

V2  
②

AVVERTENZE PER LA POSA IN OPERA DEGLI ARTICOLI FILO: posare il prodotto facendo combaciare i movimenti tridimensionali fra una piastrella e l'altra. Le frecce sul retro non sono indicative del verso di posa.

N.B. FOR ON-SITE LAYING OF THE ITEMS FILO: make sure the three-dimensional patterns of the tiles match. The arrows on the back do not indicate the laying direction.

AVERTISSEMENTS POUR LA POSE DES ARTICLES FILO: poser le produit en faisant coïncider les mouvements tridimensionnels entre un carreau et l'autre. Les flèches situées à l'arrière n'indiquent pas l'orientation de la pose.

HINWEIS FÜR DIE VERLEGUNG DER ARTIKEL FILO: Achten Sie bei der Verlegung darauf, dass die dreidimensionalen Bewegungen zwischen den Fliesen jeweils zusammenpassen. Die Pfeile auf der Rückseite geben keine Hinweise auf die Verlegerichtung.

ADVERTENCIAS PARA LA COLOCACIÓN DE LOS ARTÍCULOS FILO: colocar el producto de manera que coincidan los movimientos tridimensionales entre un azulejo y otro. Las flechas de la parte posterior no indican la dirección de colocación.

ИНСТРУКЦИИ ПО УКЛАДКЕ ПЛИТКИ FILO: расположите плитки таким образом, чтобы трехмерные мотивы на каждой из них соответствовали друг другу. Стрелки на обратной стороне не указывают на направление укладки.

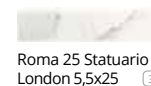

Roma 25 Statuario  
London 5,5x25 ③

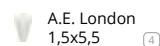

A.E. London  
1,5x5,5 ④

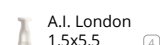

A.I. London  
1,5x5,5 ④

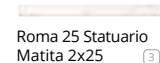

Roma 25 Statuario  
Matita 2x25 ③

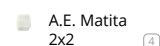

A.E. Matita  
2x2 ④

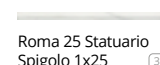

Roma 25 Statuario  
Spigolo 1x25 ③

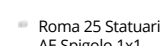

Roma 25 Statuario  
AE Spigolo 1x1 ④

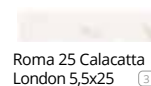

Roma 25 Calacatta  
London 5,5x25 ③

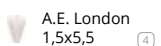

A.E. London  
1,5x5,5 ④

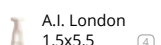

A.I. London  
1,5x5,5 ④

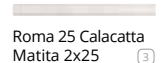

Roma 25 Calacatta  
Matita 2x25 ③

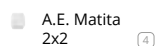

A.E. Matita  
2x2 ④



Roma 25 Calacatta  
Spigolo 1x25 ③

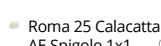

Roma 25 Calacatta  
AE Spigolo 1x1 ④

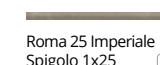
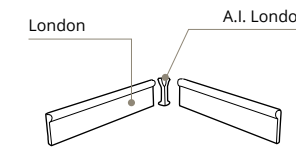
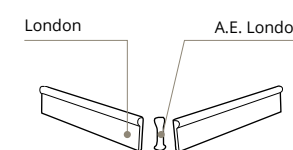

Roma 25 Imperiale  
Spigolo 1x25 ③

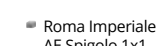

Roma Imperiale  
AE Spigolo 1x1 ④



Roma 25 Travertino  
Spigolo 1x25 ③

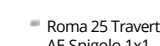

Roma 25 Travertino  
AE Spigolo 1x1 ④

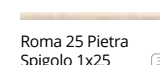

Roma 25 Pietra  
Spigolo 1x25 ③

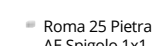

Roma 25 Pietra  
AE Spigolo 1x1 ④

|   | Unità di vendita<br>Sales unit | MQ./Box | PZ./Box | Kg/Box | Box/PL |
|---|--------------------------------|---------|---------|--------|--------|
| ① | 1 Box                          | 1,800   | 3       | 31,50  | 30     |
| ② | 1 Box                          | 1,800   | 3       | 31,80  | 30     |
| ③ | 1 Box                          | -       | 5       | -      | -      |
| ④ | 1 Box                          | -       | 4       | -      | -      |



Wall: Roma Calacatta & Fold Calacatta - Floor: Roma Calacatta Micromosaico Anticato





FRGA Roma Statuario  
25x75

V3  
1



FRHF Roma Filo Statuario  
25x75

V3  
2



FRHH Roma Fold Statuario  
25x75

V3  
2



FRFC Roma Calacatta  
25x75

V3  
1



FRHC Roma Filo Calacatta  
25x75

V3  
2



FRHG Roma Fold Calacatta  
25x75

V3  
2



FRHA Roma Imperiale  
25x75

V2  
1



FRHD Roma Filo Imperiale  
25x75

V2  
2



FRFD Roma Travertino  
25x75

V2  
1



FRER Roma Filo Travertino  
25x75

V2  
2



FRHB Roma Pietra  
25x75

V2  
1



FRHE Roma Filo Pietra  
25x75

V2  
2

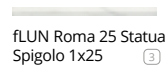

fLUN Roma 25 Statuario  
Spigolo 1x25

3

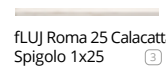

fLUJ Roma 25 Calacatta  
Spigolo 1x25

3

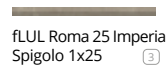

fLUL Roma 25 Imperiale  
Spigolo 1x25

3

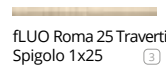

fLUO Roma 25 Travertino  
Spigolo 1x25

3

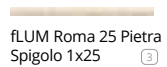

fLUM Roma 25 Pietra  
Spigolo 1x25

3

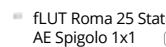

fLUT Roma 25 Statuario  
AE Spigolo 1x1

4

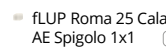

fLUP Roma 25 Calacatta  
AE Spigolo 1x1

4

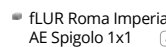

fLUR Roma Imperiale  
AE Spigolo 1x1

4



fLUU Roma 25 Travertino  
AE Spigolo 1x1

4



fLUS Roma 25 Pietra  
AE Spigolo 1x1

4

MOSAICO PASTA BIANCA  
Spessore 8,5 mm - Thickness 8,5 mm



fLTF Roma Statuario  
Mosaico 30,5x30,5\*

5

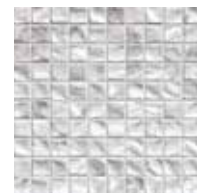

fLTL Roma Natura Statuario  
Mosaico 30,5x30,5\*\*

6



fLTB Roma Calacatta  
Mosaico 30,5x30,5\*

5



fLTH Roma Natura Calacatta  
Mosaico 30,5x30,5\*\*

6



fLTD Roma Imperiale  
Mosaico 30,5x30,5\*

5

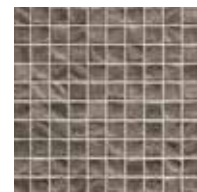

fLTJ Roma Natura Imperiale  
Mosaico 30,5x30,5\*\*

6

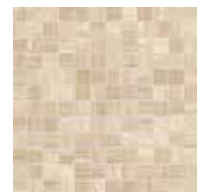

fLTG Roma Travertino  
Mosaico 30,5x30,5\*

5

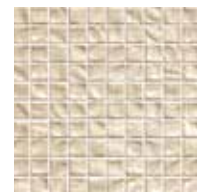

fLTM Roma Natura Travertino  
Mosaico 30,5x30,5\*\*

6

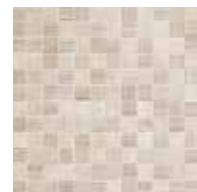

fLTE Roma Pietra  
Mosaico 30,5x30,5\*

5

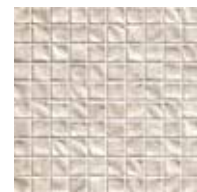

fLTK Roma Natura Pietra  
Mosaico 30,5x30,5\*\*

6



\*  
2,3 x 2,3 cm



\*\*  
2,8 x 2,8 cm

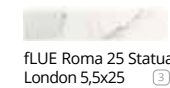

fLUE Roma 25 Statuario  
London 5,5x25

3

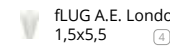

fLUG A.E. London  
1,5x5,5

4

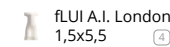

fLUI A.I. London  
1,5x5,5

4



fLZG Roma 25 Statuario  
Matita 2x25

3

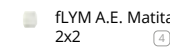

fLYM A.E. Matita  
2x2

4



fLUD Roma 25 Calacatta  
London 5,5x25

3

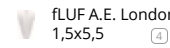

fLUF A.E. London  
1,5x5,5

4

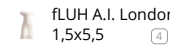

fLUH A.I. London  
1,5x5,5

4

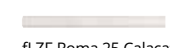

fLZF Roma 25 Calacatta  
Matita 2x25

3

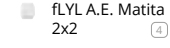

fLYL A.E. Matita  
2x2

4



fLYW Roma 25 Statuario  
Raccordo 2x25

3



fLYV Roma 25 Calacatta  
Raccordo 2x25

3



fLUW Roma 25 Statuario  
Alzata 17,5x25

4



fLUV Roma 25 Calacatta  
Alzata 17,5x25

4



fLUY Roma 25 Statuario  
A.E. Alzata 2x17,5

3



fLUX Roma 25 Calacatta  
A.E. Alzata 2x17,5

3



fLUO Roma 25 Statuario  
A.I. Alzata 2x17,5

3



fMJ5 Roma 25 Calacatta  
A.I. Alzata 2x17,5

3

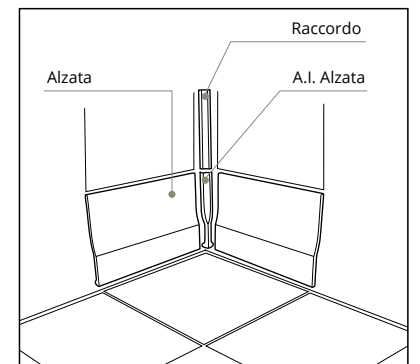
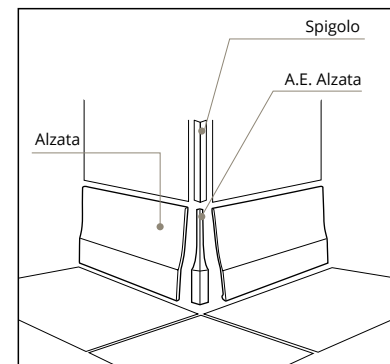
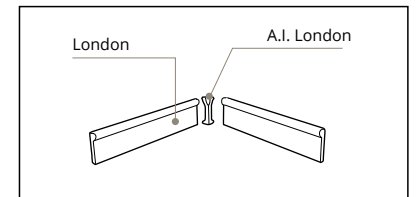
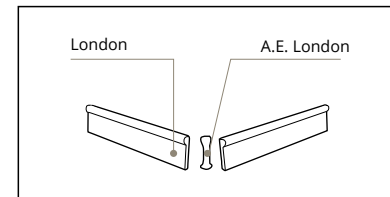

|   | Unità di vendita<br>Sales unit | MQ./Box | PZ./Box | Kg/Box | Box/PL |
|---|--------------------------------|---------|---------|--------|--------|
| 1 | 1 Box                          | 1,500   | 8       | 22,40  | 42     |
| 2 | 1 Box                          | 1,3125  | 7       | 19,95  | 42     |
| 3 | 1 Box                          | -       | 5       | -      | -      |
| 4 | 1 Box                          | -       | 4       | -      | -      |
| 5 | 1 Box                          | 0,558   | 6       | 8,20   | 84     |
| 6 | 1 Box                          | 0,558   | 6       | 8,20   | 60     |

**WallPEC**  
Classification WallPEC  
Seul le site du CSTB  
fait foi, pour vérifier  
les classements  
indiqués, merci de  
consulter le site  
<https://evaluation.cstb.fr/>





Roma Classic Statuario Inserto 25x75 ①



Roma Classic Statuario Listello 8x25 ②



Roma Classic Calacatta Inserto 25x75 ①



Roma Classic Calacatta Listello 8x25 ②



Roma Classic Pietra Inserto 25x75 ①



Roma Classic Pietra Listello 8x25 ②



Roma Fold Glitter Statuario Inserto 25x75 ①



Roma Greca Statuario Listello 8x25 ②



Roma Fold Glitter Calacatta Inserto 25x75 ①



Roma Greca Calacatta Listello 8x25 ②



Roma Greca Pietra Listello 8x25 ②



Roma Raku Listello 6x25 ②



Roma Classic Listello















Roma Raku Listello

|   | Unità di vendita<br>Sales unit | MQ./Box | PZ./Box | Kg/Box | Box/PL |
|---|--------------------------------|---------|---------|--------|--------|
| ① | 1 Box                          | -       | 4       | 12,10  | -      |
| ② | 1 Box                          | -       | 5       | 1,65   | -      |



ROMA = RM  
 ROMA DIAMOND= RD  
 ROMA GOLD= RG

|                   |   | BEIGE DUNA |      | CALACATTA |         | CALACATTA DELICATO |      | CALACATTA OHIO |      | CARRARA |         | CARRARA SUPERIORE |      | GRAFITE |      | GRIGIO SUPERIORE |      | IMPERIALE |      | NERO ELEGANTE |      | NERO REALE |      | ONICE MIELE |      | ONICE NEVE |      | PIETRA |         | STATUARIO |      | TRAVERTINO |      |
|-------------------|---|------------|------|-----------|---------|--------------------|------|----------------|------|---------|---------|-------------------|------|---------|------|------------------|------|-----------|------|---------------|------|------------|------|-------------|------|------------|------|--------|---------|-----------|------|------------|------|
|                   |   | BRILL      | MATT | BRILL     | MATT    | BRILL              | MATT | BRILL          | MATT | BRILL   | MATT    | BRILL             | MATT | BRILL   | MATT | BRILL            | MATT | BRILL     | MATT | BRILL         | MATT | BRILL      | MATT | BRILL       | MATT | BRILL      | MATT | BRILL  | MATT    | BRILL     | MATT | BRILL      | MATT |
| WALL TILES        | <br>50x120 RT 19 <sup>5/8</sup> "x47 <sup>1/4</sup> "      | RD         |      | RD        | RM      | RG                 |      | RG             |      | RD      |         | RG                |      |         |      |                  |      |           |      |               |      |            |      | RG          |      | RG         |      |        | RM      | RD        | RM   |            |      |
|                   | <br>Filo 50x120 RT 19 <sup>5/8</sup> "x47 <sup>1/4</sup> " |            |      |           | RM      |                    |      |                |      |         |         |                   |      |         |      |                  |      |           |      |               |      |            |      |             |      |            |      |        | RM      |           | RM   |            |      |
|                   | <br>Line 50x120 RT 19 <sup>5/8</sup> "x47 <sup>1/4</sup> " | RD         |      | RD        |         |                    |      |                |      | RD      |         |                   |      |         |      |                  |      |           |      |               |      |            |      |             |      |            |      |        | RD      |           |      |            |      |
|                   | <br>25x75 9 <sup>7/8</sup> "x29 <sup>1/2</sup> "           | RD         |      | RD        | RM      |                    |      |                |      | RD      |         |                   |      |         |      |                  |      |           |      |               |      |            |      |             |      |            |      |        | RM      | RD        | RM   |            | RM   |
|                   | <br>Filo 25x75 9 <sup>7/8</sup> "x29 <sup>1/2</sup> "      |            |      |           | RM      |                    |      |                |      |         |         |                   |      |         |      |                  |      |           |      |               |      |            |      |             |      |            |      |        | RM      |           | RM   |            | RM   |
|                   | <br>Fold 25x75 9 <sup>7/8</sup> "x29 <sup>1/2</sup> "      |            |      |           | RM      |                    |      |                |      |         |         |                   |      |         |      |                  |      |           |      |               |      |            |      |             |      |            |      |        | RM      |           |      |            |      |
|                   | <br>Line 25x75 9 <sup>7/8</sup> "x29 <sup>1/2</sup> "      | RD         |      | RD        |         |                    |      |                |      | RD      |         |                   |      |         |      |                  |      |           |      |               |      |            |      |             |      |            |      |        | RD      |           |      |            |      |
| GRES PORCELLANATO | <br>120x278 RT 47 <sup>1/4</sup> "x109 <sup>1/2</sup> "    | RD         |      | RD        | RM SILK | RG                 |      | RG             |      | RD      | RM SILK | RG                |      |         | RD   |                  |      |           |      |               | RG   |            |      | RG          |      | RG         |      |        | RM SILK | RD        |      |            |      |
|                   | <br>120x120 RT 47 <sup>1/4</sup> "x47 <sup>1/4</sup> "     | RD         |      | RD        |         | RG                 |      | RG             |      | RD      |         | RG                |      |         | RD   |                  |      |           |      |               |      |            |      |             |      |            |      |        | RD      |           |      |            |      |
|                   | <br>60x120 RT 23 <sup>5/8</sup> "x47 <sup>1/4</sup> "    |            |      |           |         | RG                 |      | RG             |      |         |         | RG                |      |         |      |                  |      |           |      |               |      |            |      |             |      |            |      |        |         |           |      |            |      |
|                   | <br>80x80 RT 31 <sup>1/2</sup> "x31 <sup>1/2</sup> "     | RD         |      | RD        | RM      | RG                 |      | RG             |      | RD      |         | RG                |      |         | RD   | RD               |      |           |      |               | RM   | RG         |      | RD          |      | RG         |      |        | RM      | RD        | RM   |            | RM   |
|                   | <br>60x60 RT 23 <sup>5/8</sup> "x23 <sup>5/8</sup> "     | RD         |      | RD        | RM      |                    |      |                |      | RD      |         |                   |      |         | RD   | RD               |      |           |      |               |      |            |      |             |      |            |      |        | RM      | RD        | RM   |            | RM   |
|                   | <br>30x60 RT 11 <sup>3/4</sup> "x23 <sup>5/8</sup> "     |            |      |           | RM      |                    |      |                |      |         |         |                   |      |         |      |                  |      |           |      |               |      |            |      |             |      |            |      |        | RM      |           | RM   |            | RM   |



## Gres Porcellanato - Standard ISO 13006 (EN 14411) Annex G Group BIa, Ev ≤ 0,5%

Porcelain. / Grès cerame. / Feinsteinzeug. / Gres porcelánico. / Керамогранит.

| CARATTERISTICHE TECNICHE<br>TECHNICAL SPECIFICATIONS<br>CARACTERISTIQUES TECHNIQUES<br>TECHNISCHE EIGENSCHAFTEN<br>CARACTERÍSTICAS TÉCNICAS<br>ТЕХНИЧЕСКИЕ ХАРАКТЕРИСТИКИ |  | NORME<br>STANDARDS<br>NORMES<br>NORMEN<br>NORMAS<br>НОРМЫ   | VALORE PRESCRITTO<br>VALUES REQUIRED<br>VALEUR PRESCRIPTE<br>NORMVORGABE<br>VALOR PRESCRITO<br>ЗАДАННОЕ ЗНАЧЕНИЕ<br>EN 14411 - ISO 13006 BIa (UGL e GL) | FAP - VALORE MEDIO*<br>AVERAGE RATING<br>VALEUR MOYENNE<br>DURCHSCHNITTSWERT<br>VALOR MEDIO<br>СРЕДНЕЕ ЗНАЧЕНИЕ<br>BIa UGL   |                                  |                                  |
|---|--|---|---|--|----------------------------------|----------------------------------|
|   |  |   | NON RETTIFICATO - NOT RECTIFIED   | RETTIFICATO - RECTIFIED  | MATT                             |                                  |
| DIMENSIONI<br>SIZES<br>DIMENSIONS<br>GRÖSSEN<br>DIMENSIONES<br>РАЗМЕРЫ  |  | <b>Lunghezza e larghezza</b><br>Length and width / Dimensions des côtés / Seitenlänge / Largo y ancho / Длина и ширина  | ± 0,6%, max 2 mm  | ± 0,3%, max 1 mm   | <b>Conforme</b><br>In accordance |                                  |
|   |  | <b>Spessore</b><br>Thickness / Epaisseur / Stärke / Espesor / Толщина   | ± 5%, max 0,5 mm  | ± 5%, max 0,5 mm   | <b>Conforme</b><br>In accordance |                                  |
|   |  | <b>Ortogonalità **</b><br>Wedging / Orthogonalité / Rechtwinkligkeit / Ortogonalidad / Ортогональность  | ± 0,5%, max 2 mm  | ± 0,3%, max 1,5 mm   | <b>Conforme</b><br>In accordance |                                  |
|   |  | Rettilinearità degli spigoli / Straightness of the edges / Equerrage des angles / Kantengeradheit / Rectilinearidad de las aristas / Прямолинейность углов  | ± 0,5%, max 1,5 mm  | ± 0,3%, max 0,8 mm   | <b>Conforme</b><br>In accordance |                                  |
|   |  | <b>Planarità</b><br>Flatness / Planéité / Oberflächenqualität / Planicidad / Плоскостность  | ± 0,5%, max 2 mm  | ± 0,4%, max 1,8 mm   | <b>Conforme</b><br>In accordance |                                  |
| STRUTTURA<br>STRUCTURE<br>STRUCTURE<br>STRUKTUR<br>ESTRUCTURA<br>СТРУКТУРА  |  | <b>Assorbimento d'acqua - valore medio %</b><br>Water absorption - average value % / Absorption d'eau - valeur moyenne % / Wasseraufnahme - Durchschnittswert % / Absorción de agua - valor medio % / Водопоглощение Среднее значение %   | ISO 10545-3<br>ASTM C373  | ≤ 0,5%   | <b>Conforme</b><br>In accordance |                                  |
|   |  | <b>Sforzo di rottura</b> Breaking strength / Force de rupture / Bruchlast / Esfuerzo di ruptura / Усилие на излом   | ISO 10545-4   | S ≥ 1300 N   | S ≥ 2000 N                       |                                  |
|   |  | <b>Resistenza alla flessione</b><br>Bending strength / Résistance à la flexion / Biegefestigkeit / Resistencia a la flexión / Прочность при изгибе  | ISO 10545-4   | R ≥ 35 N/mm <sup>2</sup>   |                                  | <b>Conforme</b><br>In accordance |
|   |  | <b>Abrasion profonda</b> Deep abrasion / Abrasion profonde / Tiefenabrieb / Abrasión profunda / Глубокое истирание  | ISO 10545-6   | ≤ 175mm <sup>3</sup>   | ≤ 140mm <sup>3</sup>             |                                  |
| SBALZI TERMICI<br>THERMAL SHOCK<br>ECARTS DE TEMPERATURE<br>TEMPERATURWECHSEL<br>CHOQUES TÉRMICOS<br>ТЕМПЕРАТУРНЫЕ ПЕРЕПАДЫ   |  | <b>Coefficiente di dilatazione termica lineare</b><br>Coefficient of thermal linear expansion / Coefficient de dilatation thermique linear / Wärmeausdehnungskoeffizient / Coeficiente de dilatación termica linear / Коэффициент теплового линейного расширения  | ISO 10545-8   | Valore dichiarato<br>Declared Value / Valeur déclarée / Angegebener Wert / Valor declarado / Объявленная ценность  | ≤ 7 МК <sup>-1</sup>             |                                  |
|   |  | <b>Resistenza agli sbalzi termici</b><br>Thermal shock resistance / Resistance aux variations thermiques / Temperaturwechselbeständigkeit / Resistencia a las diferencias de temperatura / Сопротивление температурным перепадам  | ISO 10545-9   | Resistente<br>Resistant  |                                  | <b>Resistente</b><br>Resistant   |
|   |  | <b>Resistenza al gelo</b><br>Resistance to frost / Résistance au gel / Frostbeständigkeit / Resistencia al hielo / Морозоустойчивость   | ISO 10545-12  | Resistente<br>Resistant  |                                  | <b>Resistente</b><br>Resistant   |
| SICUREZZA<br>SAFETY<br>SÉCURITÉ<br>SICHERHEIT<br>SEGURIDAD<br>БЕЗОПАСНОСТЬ  |  | <b>Coefficiente di attrito dinamico</b><br>Dynamic friction coefficient / Coefficient de frottement dynamique / Dynamischer Reibungskoeffizient / Coeficiente de fricción dinámico / Динамический коэффициент трения  | DCOF BOT 3000   | Slip resistant ≥ 0,42  | <b>Conforme</b><br>In accordance |                                  |
|   |  | <b>Coefficiente di attrito dinamico</b><br>Dynamic friction coefficient / Coefficient de frottement dynamique / Dynamischer Reibungskoeffizient / Coeficiente de fricción dinámico / Динамический коэффициент трения  | DIN 51130   | In funzione dell'ambiente o della zona di lavoro.<br>According to the space or the working area / Selon le lieu concerné ou la zone de travail / Je nach Raum oder Arbeitszone / Según el ambiente o de la zona de trabajo / В зависимости от среды или рабочей зоны   | R9                               |                                  |
|   |  | <b>Classificazione antiscivolo</b><br>Non-slip classification / Classification antiderapant / Bewertungsgruppe trittsicherheit / Clasificación antideslizante / Классификация противоскольжения   | DIN 51097   | In funzione delle zone bagnate soggette a calpestio a piedi nudi.<br>According to the wet area to be stepped on barefoot / Selon le type de surface mouillée parcourue pieds nus. / Je nach Nassbereich die barfuß zu betreten sind / Según de la zona mojada que se pisa con los pies desnudos / С учётом увлажняемых зон, предназначенных для ходьбы босиком |                                  |                                  |
| RESISTENZA CHIMICA<br>CHEMICAL RESISTANCE<br>RÉSISTANCE AUX ATTAQUES CHIMIQUES<br>CHEMIKALIENFESTIGKEIT<br>RESISTENCIA A LOS PRODUCTOS QUÍMICOS<br>ХИМИЧЕСКАЯ СТОЙКОСТЬ   |  | <b>Resistenza ai prodotti chimici di uso domestico e agli additivi per piscina</b><br>Resistance to household chemicals and swimming pool salts / Résistance aux produits chimiques à usage domestique et aux adjuvants pour piscines / Beständigkeit gegen Haushaltchemikalien und Badewasserzusätze / Resistencia a los productos químicos de uso domestico o productos para la piscina / Сопротивляемость химическим средствам домашнего применения и добавкам для бассейна. | ISO 10545-13  | MINIMUM B  | <b>Conforme</b><br>In accordance |                                  |
|   |  | <b>Resistenza a basse concentrazioni di acidi ed alcali</b><br>Resistance to low concentrations of acids and alkalis / Résistance aux acides et aux alcalis à basse concentration / Beständigkeit gegen niedrigkonzentrierte Säuren und Laugen / Resistencia a concentración baja de ácidos y álcali / Сопротивляемость кислотам и щелочам низкой концентрации  |   | Secondo la classificazione indicata dal fabbricante.<br>According to classification indicated by the manufacturer / Second la classification indiquée par le fabricant / Je nach der angegebenen Fabrikantenbewertung / Según la clasificación indicada del fabricante / Согласно классификации, указанной производителем.                                     |                                  | LB Min.                          |
|   |  | <b>Resistenza alle macchie</b><br>Stain resistance / Résistance aux taches / Baständigkeit gegen Fleckenbildung / Resistencia a las manchas / Стойкость к загрязнению   | ISO 10545-14  | UGL: Metodo di prova disponibile / Test method available / Méthode d'essai disponible / Verfügbare Prüfmethode / Método de prueba disponible / Доступный метод испытания<br>GL: Minimum 3  |                                  | 5                                |

\* Valore medio dei test condotti negli ultimi 24 mesi. Average rating of tests conducted during the last 24 months. Durchschnittswert der in den letzten 24 Monaten durchgeführten Tests. Valeur moyenne des essais menés au cours des 24 derniers mois. Valor medio de las pruebas llevadas a cabo en los últimos 24 meses. Среднее значение испытаний, проведенных в течение последних 24 месяцев.

\*\* Per piastrelle rettangolari, che abbiano il lato maggiore L ≥ 60 cm, e rapporto tra i lati ≥ 3, la misurazione della ortogonalità deve venire condotta solo sul lato corto. For oblong tiles with L ≥ 60 cm and ratio length/width L/W ≥ 3, measurement of rectangularity only on short edges

## Wall Tiles - Standard ISO 13006 (EN 14411) Annex L Group BIII, Ev &gt; 10%

Pasta Bianca. / White body. / Weißscherbiger. / Pâte blanche. / Pasta blanca. / Белой глины.

| CARATTERISTICHE TECNICHE<br>TECHNICAL SPECIFICATIONS<br>CARACTERISTIQUES TECHNIQUES<br>TECHNISCHE EIGENSCHAFTEN<br>CARACTERÍSTICAS TÉCNICAS<br>ТЕХНИЧЕСКИЕ ХАРАКТЕРИСТИКИ |  | NORME<br>STANDARDS<br>NORMES<br>NORMEN<br>NORMAS<br>НОРМЫ   | VALORE PRESCRITTO<br>VALUES REQUIRED<br>VALEUR PRESCRIPTE<br>NORMVORGABE<br>VALOR PRESCRITO<br>ЗАДАННОЕ ЗНАЧЕНИЕ<br>EN 14411 - ISO 13006 BIII (GL) | VALORE MEDIO FAP*<br>AVERAGE FAP RATING<br>VALEUR MOYENNE FAP<br>DURCHSCHNITTSWERT FAP<br>VALOR MEDIO FAP<br>СРЕДНЕЕ ЗНАЧЕНИЕ FAP<br>BIII (GL)                              |                                  |                                  |
|---|--|---|--|---|----------------------------------|----------------------------------|
|   |  |   | NON RETTIFICATO - NOT RECTIFIED  | RETTIFICATO - RECTIFIED   | TUTTI I FORMATI - ALL SIZES      |                                  |
| DIMENSIONI<br>SIZES<br>DIMENSIONS<br>GRÖSSEN<br>DIMENSIONES<br>РАЗМЕРЫ  |  | <b>Lunghezza e larghezza</b><br>Length and width / Dimensions des côtés / Seitenlänge / Largo y ancho / Длина и ширина  | ± 0,6%, max 2 mm   | ± 0,3%, max 1 mm  | <b>Conforme</b><br>In accordance |                                  |
|   |  | <b>Spessore</b><br>Thickness / Epaisseur / Stärke / Espesor / Толщина   | ± 10%, max 0,5 mm  | ± 10%, max 0,5 mm   | <b>Conforme</b><br>In accordance |                                  |
|   |  | <b>Ortogonalità **</b><br>Wedging / Orthogonalité / Rechtwinkligkeit / Ortogonalidad / Ортогональность  | ± 0,5%, max 2 mm   | ± 0,3%, max 1,5 mm  | <b>Conforme</b><br>In accordance |                                  |
|   |  | <b>Rettilinearità degli spigoli</b> Straightness of the edges / Equerrage des angles / Kantengeradheit / Rectilinearidad de las aristas / Прямолинейность углов   | ± 0,5%, max 1,5 mm   | ± 0,3%, max 0,8 mm  | <b>Conforme</b><br>In accordance |                                  |
|   |  | <b>Planarità</b><br>Flatness / Planéité / Oberflächenqualität / Planicidad / Плоскостность  | ± 0,5%, max 2 mm   | ± 0,4%, max 1,8 mm  | <b>Conforme</b><br>In accordance |                                  |
| STRUTTURA<br>STRUCTURE<br>STRUCTURE<br>STRUKTUR<br>ESTRUCTURA<br>СТРУКТУРА  |  | <b>Aspetto della superficie % senza difetti nel lotto di prova</b><br>Quality of the surface Faultless % within the sample lot / Qualité de la surface % sans défauts dans le lot d'essai / Oberflächenqualität % an fehlerfreien Fliesen im Prüfbett / Aspecto de la superficie % sin defectos en el lote de prueba / Вид поверхности % без брака в пробной партии   | ≥ 95%  |   | <b>Conforme</b><br>In accordance |                                  |
|   |  | <b>Assorbimento d'acqua - valore medio %</b><br>Water absorption - average value % / Absorption d'eau - valeur moyenne % / Wasseraufnahme - Durchschnittswert % / Absorción de agua - valor medio % / Водопоглощение Среднее значение %   | ISO 10545-3  | > 10%   |                                  | <b>Conforme</b><br>In accordance |
|   |  | <b>Sforzo di rottura</b> Breaking strength / Force de rupture / Bruchlast / Esfuerzo di ruptura / Усилие на излом   | ISO 10545-4  | S ≥ 600 N   |                                  | <b>Conforme</b><br>In accordance |
| SBALZI TERMICI<br>THERMAL SHOCK<br>ECARTS DE TEMPERATURE<br>TEMPERATURWECHSEL<br>CHOQUES TÉRMICOS<br>ТЕМПЕРАТУРНЫЕ ПЕРЕПАДЫ   |  | <b>Resistenza alla flessione</b><br>Bending strength / Résistance à la flexion / Biegefestigkeit / Resistencia a la flexión / Прочность при изгибе  |  | R ≥ 12 N / mm <sup>2</sup>  | <b>Conforme</b><br>In accordance |                                  |
|   |  | <b>Resistenza agli sbalzi termici</b><br>Thermal shock resistance / Resistance aux variations thermiques / Temperaturwechselbeständigkeit / Resistencia a las diferencias de temperatura / Сопротивление температурным перепадам  | ISO 10545-9  | <b>Conforme</b><br>In accordance  |                                  | <b>Conforme</b><br>In accordance |
| SUPERFICIE<br>SURFACE<br>OBERFLÄCHE<br>SUPERFICIE<br>ПОВЕРХНОСТЬ  |  | <b>Resistenza al cavillo</b><br>Crazing resistance / Résistance aux craquelures / Haarriß-Beständigkeit / Resistencia al cuarteado / Сопротивляемость образованию кракелюров  | ISO 10545-11   | <b>Conforme</b><br>In accordance  | <b>Conforme</b><br>In accordance |                                  |
|   |  | <b>Resistenza ai prodotti chimici di uso domestico e agli additivi per piscina</b><br>Resistance to household chemicals and swimming pool salts / Résistance aux produits chimiques à usage domestique et aux adjuvants pour piscines / Beständigkeit gegen Haushaltchemikalien und Badewasserzusätze / Resistencia a los productos químicos de uso domestico o productos para la piscina / Сопротивляемость химическим средствам домашнего применения и добавкам для бассейна. |  | B Min.  |                                  | <b>Conforme</b><br>In accordance |
|   |  | <b>Resistenza a basse concentrazioni di acidi ed alcali</b><br>Resistance to low concentrations of acids and alkalis / Résistance aux acides et aux alcalis à basse concentration / Beständigkeit gegen niedrigkonzentrierte Säuren und Laugen / Resistencia a concentración baja de ácidos y álcali / Сопротивляемость кислотам и щелочам низкой концентрации  | ISO 10545-13   | <b>Metodo di prova disponibile</b><br>Test method available / Méthode d'essai disponible / Verfügbare Prüfmethode / Método de prueba disponible / Доступный метод испытания |                                  | LB Min.                          |
| RESISTENZA CHIMICA<br>CHEMICAL RESISTANCE<br>RÉSISTANCE AUX ATTAQUES CHIMIQUES<br>CHEMIKALIENFESTIGKEIT<br>RESISTENCIA A LOS PRODUCTOS QUÍMICOS<br>ХИМИЧЕСКАЯ СТОЙКОСТЬ   |  | <b>Resistenza alle macchie</b><br>Stain resistance / Résistance aux taches / Baständigkeit gegen Fleckenbildung / Resistencia a las manchas / Стойкость к загрязнению   | ISO 10545-14   | MINIMUM CLASS 3   | 5                                |                                  |

\* Valore medio dei test condotti negli ultimi 24 mesi. Average rating of tests conducted during the last 24 months. Durchschnittswert der in den letzten 24 Monaten durchgeführten Tests. Valeur moyenne des essais menés au cours des 24 derniers mois. Valor medio de las pruebas llevadas a cabo en los últimos 24 meses. Среднее значение испытаний, проведенных в течение последних 24 месяцев.

\*\* Per piastrelle rettangolari, che abbiano il lato maggiore L ≥ 60 cm, e rapporto tra i lati ≥ 3, la misurazione della ortogonalità deve venire condotta solo sul lato corto. For oblong tiles with L ≥ 60 cm and ratio length/width L/W ≥ 3, measurement of rectangularity only on short edges



# VSHADE

La classificazione V-Shade indica il livello di stonizzazione del prodotto, classificato da V0 a V4.

The V-Shade classification indicates the level of shading of the product, ranked from V0 to V4.

**V0**

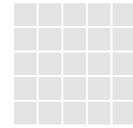

Nessuna  
None

Aucune  
Keine  
Ninguna  
нулевой

**V1**

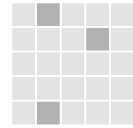

Leggera  
Light

Légère  
Leicht  
Ligera  
Низкий

**V2**

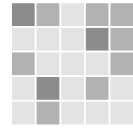

Moderata  
Moderate

Modérée  
Mäßig  
Moderada  
Средний

**V3**



Alta  
High

Élevée  
Hoch  
Alta  
Значительный

**V4**

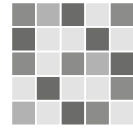

Forte  
Very High

Forte  
Stark  
Fuerte  
Высокий

Le classement V-shade indique le niveau de mouvement chromatique au sein d'un produit. Il va de V0 à V4.

Die V-Shade-Einstufung gibt die Farbunterschiede zwischen Fliesen einer Kollektion an, die Kategorien sind V0 bis V4.

La clasificación V-Shade indica el nivel de destonación del producto, clasificado de V0 a V4.

Согласно классификации V-Shade, указывающей на уровень цветовой неоднородности изделия, нашей плитке были присвоены значения от V0 до V4.

Per tutte le istruzioni di posa, pulizia e smaltimento, consultare il sito [www.fapceramiche.com](http://www.fapceramiche.com) alla sezione Faq.  
For full instructions on installation, cleaning and disposal, consult the FAQ section on the [www.fapceramiche.com](http://www.fapceramiche.com).  
Pour toutes les instructions de pose, de nettoyage et d'élimination, consultez le site [www.fapceramiche.com](http://www.fapceramiche.com) à la section FAQ.  
Für alle Anweisungen für das Verlegen, Reinigen und Entsorgen besuchen Sie bitte die Website [www.fapceramiche.com](http://www.fapceramiche.com) im Bereich FAQ.  
Puede consultar todas las instrucciones de colocación, limpieza y eliminación en la sección de preguntas frecuentes (FAQ) del sitio web [www.fapceramiche.com](http://www.fapceramiche.com).  
Для любой информации по укладке, очистке и утилизации посетите страницу Частых Вопросов на сайте [www.fapceramiche.com](http://www.fapceramiche.com).

I colori e le caratteristiche estetiche dei materiali illustrati nel presente catalogo sono da ritenersi puramente indicativi.  
Colours and optical features of the materials illustrated in this catalogue are to be regarded as mere indications.  
Die Farben und die ästhetischen Eigenschaften der in diesem Katalog abgebildeten Produkte sind als reine Richtwerte zu betrachten.  
Les coloris et les caractéristiques esthétiques des références illustrées dans le catalogue sont donnés à titre purement indicatif.  
Los colores y las características ópticas de los materiales ilustrados en este catalogo deben ser mirados como indicaciones meras.  
Цвета и эстетические характеристики описанных в настоящем каталоге материалов являются только ориентировочными.

Fap ceramiche si riserva di apportare modifiche e/o eliminare senza preavviso i prodotti declinando ogni responsabilità per danni diretti o indiretti derivanti da eventuali modifiche.  
Fap ceramiche can change the indicated products without notice declining any responsibility for direct or indirect damage that depend on these changes.  
Fap ceramiche se réserve le droit de modifier sans préavis les produits indiqués et décline toute responsabilité pour dommages directs ou indirects dus à éventuelles modifications.  
Fap Ceramiche se reserva la facultad de modificar los productos sin preaviso, declinando cualquier responsabilidad por daños directos o indirectos que dependan de estos cambios.  
Fap ceramiche kann die genannten Produkten ändern ohne Voranmeldung und lehnt dabei jegliche Verantwortung für die davon abhängenden direkten oder indirekten Schäden ab.  
Компания "Fap ceramiche" сохраняет за собой право на внесение изменений в продукцию без предварительного уведомления, снимая с себя всякую ответственность за связанный с этими изменениями прямой или не прямой ущерб.

Fap ceramiche - 4<sup>th</sup> edition October 2023 - 1<sup>st</sup> edition September 2015

È vietata la riproduzione anche parziale dell'opera in tutte le sue forme.  
Reproduction of this printed catalogue, even partially, is prohibited.



17889-1  
Certified by DNV







Via Ghiarola Nuova, 44 - 41042 Fiorano Modenese (MO) Italy  
tel. +39 0536 837511 - fax +39 0536 837532 - fax estero +39 0536 837542  
[www.fapceramiche.com](http://www.fapceramiche.com) - [info@fapceramiche.com](mailto:info@fapceramiche.com)

